

Desoldering Gun Temperature Control. MODEL NO. : TP-100/TP-100AS

Features/Specifications :

- Input 220-240V AC, Power Consumption 95W.
- 80 Watt Ceramic Heater for superior heating capacity.
- Insulation resistance over 100M .
- In-built vacuum Pump diaphragm.
- Temp. Range Desoldering Unit (250-450°C).
- Dimensions : Control unit 225 x 170 mm, Weight : 470 gm.
- Quick suction 600mm Hg in 0.5 sec only.
- Unbreakable long life Cartridge.
- HIGH MASS nozzle ensure efficient heat transfer.
- Ultra long life nozzles variety of shape. For nozzles shape, Refer TP-100N- Series
- Zero volt switching ensure low noise & keeps tip temp. stable.
- Carry Case, Filter & Cleaning pin as standard.
- Ideal for field work on PTH / Multilayer PCB.
- Stand Model ST-77 Optional, Please refer Page no.10

From : goot, Japan Warranty : 1 year AMD



TP-100AS is antistatic version

Bench Top Anti-Static Desoldering Station

MODEL NO. : TP-200

Features/Specification :

- Input 220-240V AC, Power Consumption 110 W.
- Double pump high capacity motor.
- Low weight hand piece.
- 80 Watt Ceramic Heater for superior heating capacity.
- Insulation resistance over 100M .
- In-built vacuum Pump diaphragm (Twin Pump).
- Ripple Temp. Without Load $\pm 3^{\circ}\text{C}$, Leakage Voltage Less than 0.1mV.
- Ground Resistance Less than 0.3 .
- Temp. Range (250-450°C).
- Unbreakable long life Cartridge.
- Quick suction 600mm Hg in 0.5 sec.
- HIGH MASS nozzle ensure efficient heat transfer.
- Zero volt switching ensure low noise & keeps tip temp. Stable.
- Ultra long life nozzles variety of shape. For nozzles shape, refer TP-100N- Series.
- Vacuum continue for 0.5 sec after release of trigger ensure molten solder in cartridge (Pat.). To avoid solder jamming in nozzle.
- Heating power booster to compensate offset of heating (Pat.).
- Stand Model ST-76 Standard.
- Dimensions : Control unit 95 (W) x 256 (L) x 205 (H) mm,
- Weight : Desoldering Gun 300 gm without coard, Control Unit 2.6 kg.

From : goot, Japan Warranty : 1 year AMD



Anti-Static Combined Soldering Desoldering Service Station. MODEL NO. SVS-500

Features/Specification :

- Input 220-240V AC, Power Consumption 300W.
- Double pump high capacity motor, Low weight hand piece.
- 80 Watt Ceramic Heater for superior heating capacity in desoldering & 70W for soldering.
- Insulation resistance over 100M .
- In-built vacuum Pump diaphragm (Twin Pump).
- Ripple Temp. Without Load $\pm 3^{\circ}\text{C}$, Leakage Voltage Less than 0.1mV.
- Ground Resistance Less then 0.3 .
- Temp. Range Desoldering Unit (250-450 $^{\circ}\text{C}$), Soldering unit (200-480 $^{\circ}\text{C}$).
- Unbreakable long life Cartridge.
- Quick Suction 600mm Hg in 0.5 sec.
- HIGH MASS nozzle ensure efficient heat transfer.
- Ultra long life nozzles variety of shape. For nozzles shape, refer TP-100N- Series & for soldering PX-2RT-Series
- Zero volt switching ensure low noise & keeps tip temp. stable.
- Vacuum continue for 0.5 sec after release of trigger ensure molten solder in cartridge (Pat.) . To avoid Solder jamming in nozzle.
- Heating power booster to compensate offset of heating.
- Stand for soldering and desoldering is standard included.
- Dimensions : Control unit 205 (W) x 160 (L) x 170 (H) mm,
- Weight : Soldering unit 45 gm., Desoldering Gun 300 gm., Control Unit 3.6 kg. total wt. approximately 4Kg.



From : goot, Japan Warranty : 1 year AMD

Soldering Tips SVS-500 Iron Unit

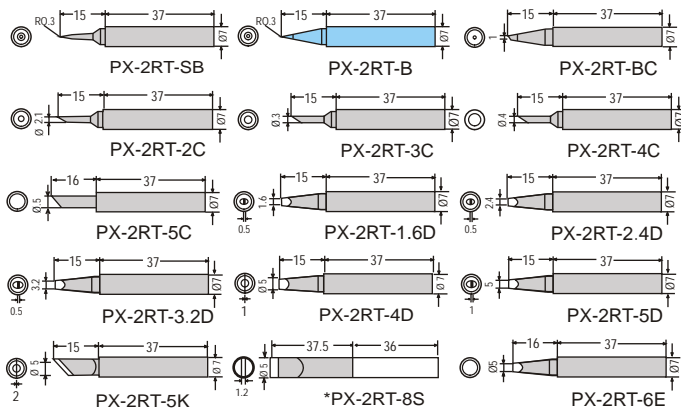

Desoldering Tips for TP-100, SVS-500, TP-200

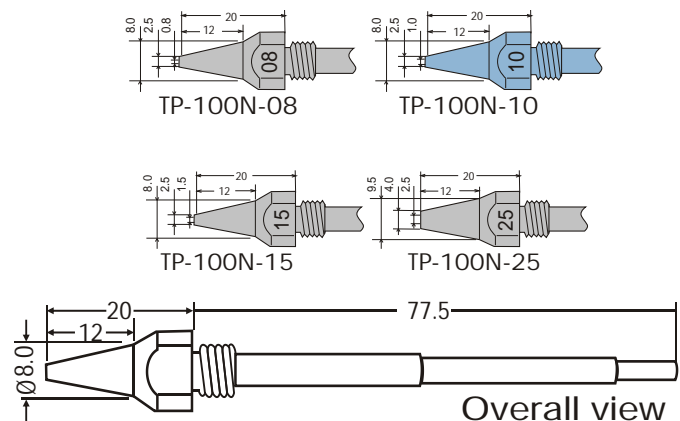

Web : www.advancetechonline.in

ADVANCE TECH SERVICES PVT. LTD. 709-710, GD-ITL Towers, B-8, Netaji Subhash Place, Pitampura, Ring Road, New Delhi 110 034 Ph : 011-47002024 upto 27, Fax : 011-47002029E-Mail : info@advancetechonline.in web:www.advancetechonline.in **B.O. : ? Bangalore ? Pune**

PRODUCT RANGE: Soldering Desoldering for SMD/PTH, Solder POT, Electric Screw Drivers, Pneumatic Screw Driver, Torque Meter, Screw Torque deciders, Screw Feeders, Balancer, Torque Arm, Air Dispenser, Air Free Dispenser, Syringes and Barrel for dispenser, Flux, Spray Fluxer, Desolder Wick, Static Charge Meter, Ionizers, Ion Gun, Illuminated Magnifiers, Hand tools (Cutter, strippers, Pliers, crimper, Cable cutters etc.. ESD Products, Peelable Mask, Solder Bath Treatment, Rework Pens (Conductive pen, flux pen, green over coat pen, conformal coating remover pen), Imported stations soldering bits, Bit Cleaning sponge, Screw driver bits and many more.....